



TE3112 Operators Manual

Identification Heat Shrink and Label Printer

EIL/MAN/033/ Rev 1

Copyright

This documentation as well as translation hereof are property of Tyco Electronics UK Ltd.

The replication, conversion, duplication or divulgement of the whole manual or parts of it for other intentions than its original intended purpose demand the previous written authorization by Tyco Electronics UK Ltd.

Trademark

Centronics® is a registered trademark of the Data Computer Corporation.

Microsoft® is a registered trademark of the Microsoft Corporation.

Windows 2000®, 2003®, XP® are registered trademarks of the Microsoft Corporation.

TrueType™ is a registered trademark of Apple Computer, Inc.

Topicality

Due to the constant further development of our products discrepancies between documentation and product can occur.

Terms and conditions

Deliveries and performances are effected under the General conditions of sale of Tyco Electronics UK Ltd.

1	Introduction	4
1.1	Instructions	4
1.2	Intended Use	4
1.3	Safety Instructions	4
1.4	Environment	5
2	Installation	6
2.1	Device Overview	6
2.2	Unpacking and Setting-up the Printer	8
2.3	Connecting the Device	8
2.3.1	Connecting to the Power Supply	8
2.3.2	Connecting to a Computer or Computer Network	8
2.4	Switching on the Device	8
3	Control Panel	9
3.1	Structure of the Control Panel	9
3.2	Symbol Displays	9
3.3	Printer States	10
3.4	Key Functions	11
4	Loading Material	12
4.1	Loading Labels or Continuous Media from Roll	12
4.1.1	Positioning the Media Roll on the Roll Retainer	12
4.1.2	Inserting a Media Strip into the Printhead	13
4.1.3	Setting the Label Sensor	13
4.2	Loading Fanfold Labels	14
4.3	Loading Transfer Ribbon	15
4.4	Setting the Feed Path of the Transfer Ribbon	16
4.5	Setting the Head Locking System	16
5	Printing Operation	17
6	Cleaning	18
6.1	Cleaning Information	18
6.2	Cleaning the Print Roller	18
6.3	Cleaning the Printhead	18
7	Fault Correction	19
7.1	Types of Errors	19
7.2	Problem Solution	19
7.3	Error Messages and Fault Correction	20
8	Media	22
8.1	Media Dimensions	22
8.2	Device Dimensions	23
8.3	Reflex Mark Dimensions	24
8.4	Cut-out Mark Dimensions	25
9	Licences	26
9.1	EU Declaration of Conformity	26
9.2	Other Licences	26
10	Index	27

1.1 Instructions

Important information and instructions in this documentation are designated as follows:



Danger!

Draws your attention to an exceptionally grave, impending danger to your health or life.



Warning!

Indicates a hazardous situation that could lead to injuries or material damage.



Attention!

Draws attention to possible dangers, material damage or loss of quality.



Notice!

Gives you tips. They make a working sequence easier or draw attention to important working processes.



Environment!

Gives you tips on protecting the environment.



Handling instruction



Reference to section, position, illustration number or document.



Option (accessories, peripheral equipment, special fittings).

1.2 Intended Use

- The device is manufactured in accordance with the current technological status and the recognized safety rules. However, danger to the life and limb of the user or third parties and/or damage to the device and other tangible assets can arise during use.
- The device may only be used for its intended purpose and if it is in perfect working order, and it must be used with regard to safety and dangers as stated in the operating manual.
- The device printer is intended exclusively for printing suitable materials that have been approved by the manufacturer. Any other use or use going beyond this shall be regarded as improper use. Tyco Electronics shall not be liable for damage resulting from unauthorized use; the user shall bear the risk alone.
- Usage for the intended purpose also includes complying with the operating manual, including the manufacturer's maintenance recommendations and specifications.



Notice!

The complete documentation is included in the scope of delivery on CD ROM.

1.3 Safety Instructions

- The device is configured for voltages of 100 to 240 V AC. It only has to be plugged into a grounded socket.
- Only connect the device to other devices which have a protective low voltage.
- Switch off all affected devices (computer, printer, accessories) before connecting or disconnecting.
- The device may only be used in a dry environment, do not expose it to moisture (sprays of water, mists, etc.).
- Do not use the device in an explosive atmosphere.
- Do not use the device close to high-voltage power lines.
- If the device is operated with the cover open, ensure that people's clothing, hair, jewelry etc. do not come into contact with the exposed rotating parts.
- The device or parts of it can become hot while printing. Do not touch during operation, and allow to cool down before changing material and before disassembly.

- Risk of crushing when closing the cover. Touch the cover at the outside only. Do not reach into the swivel range of the cover.
- Perform only those actions described in this operating manual.
Work going beyond this may only be performed by trained personnel or service technicians.
- Unauthorized interference with electronic modules or their software can cause malfunctions.
- Other unauthorized work on or modifications to the device can also endanger operational safety.
- Always have service work done in a qualified workshop, where the personnel have the technical knowledge and tools required to do the necessary work.
- There are various warning stickers on the device. They draw your attention to dangers.
Warning stickers must therefore not be removed, as then you and other people cannot be aware of dangers and may be injured.
- The maximum sound pressure level is less than 70 dB(A).



Danger!

Danger to life and limb from power supply.

- ▶ **Do not open the device casing.**

1.4 Environment



Obsolete devices contain valuable recyclable materials that should be sent for recycling.

- ▶ Send to suitable collection points, separately from residual waste.

The modular construction of the printer enables it to be easily disassembled into its component parts.

- ▶ Send the parts for recycling.

The electronic circuit board of the device is equipped with a lithium battery.

- ▶ Take old batteries to collection boxes in shops or public waste disposal centers.

2.1 Device Overview

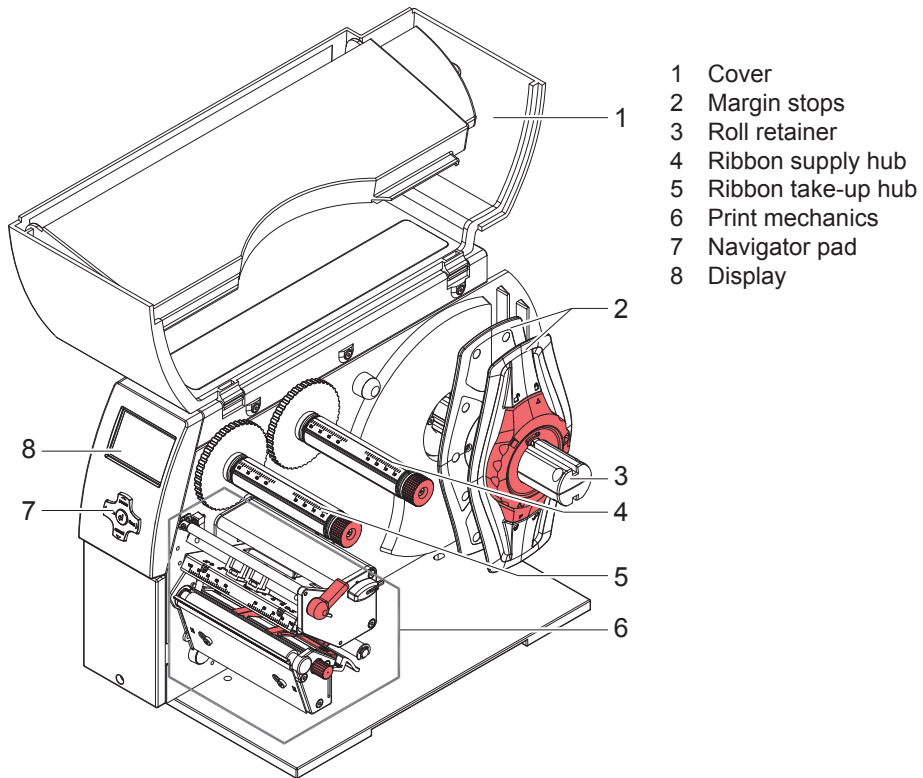

Fig. 1 Overview

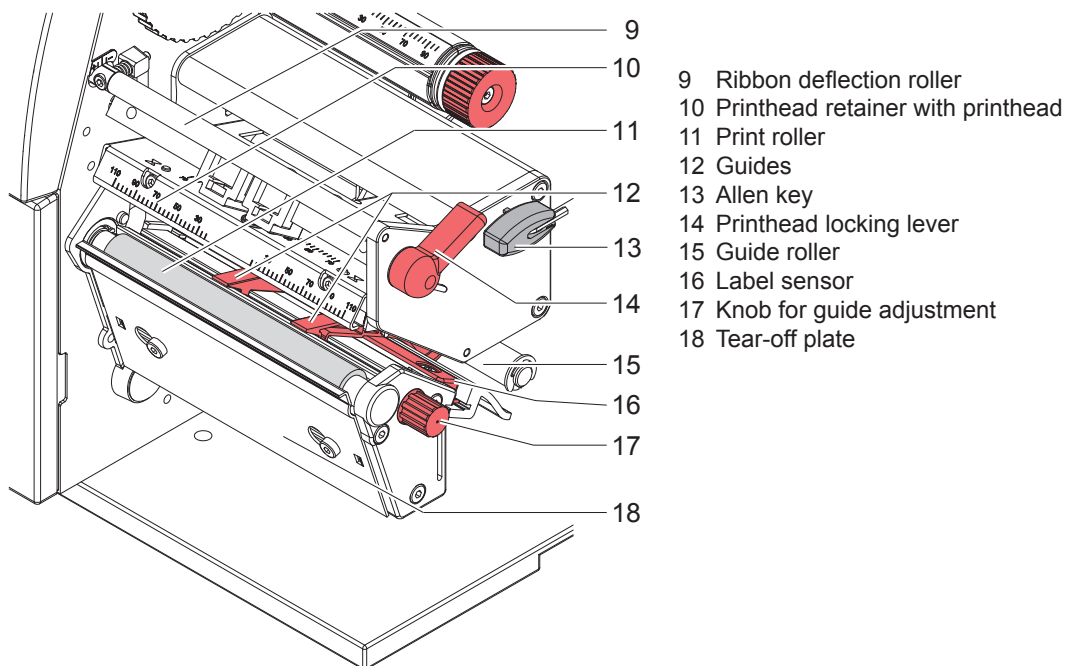
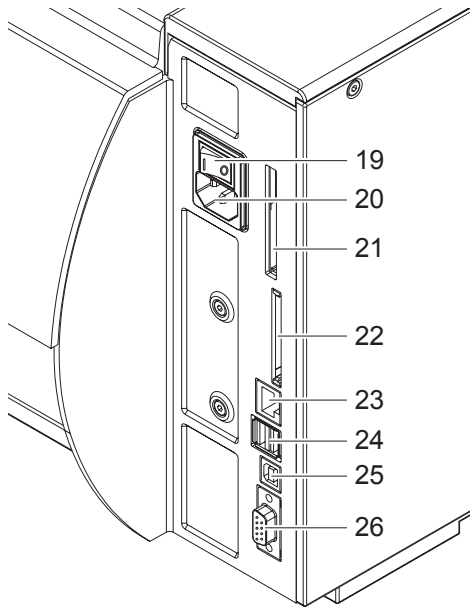

Fig. 2 Print mechanics



- 19 Power switch
- 20 Power connection jack
- 21 Slot for PC Card Type II
- 22 Slot for CompactFlash memory card
- 23 Ethernet 10/100 Base-T
- 24 2 USB master ports for keyboard,
scanner or service key
- 25 USB high-speed slave port
- 26 Serial RS-232 C port

Fig. 3 Connections

2.2 Unpacking and Setting-up the Printer

- ▶ Check label printer for damage which may have occurred during transport.
- ▶ Set up printer on a level surface.
- ▶ Remove foam transportation safeguards near the printhead.
- ▶ Check delivery for completeness.

Contents of delivery:

- Label printer
- Power cables
- USB cable
- Documentation
- Print Easy and Wintotal Demo on CD-ROM
- Documentation on CD-ROM

Notice!



Please keep the original packaging in case the printer must be returned.

Attention!



The device and printing materials will be damaged by moisture and wetness.

- ▶ Set up label printers only in dry locations protected from splash water.

2.3 Connecting the Device

The standard available interfaces and connectors are shown in figure 3.

2.3.1 Connecting to the Power Supply

The printer is equipped with a wide area power unit. The device can be operated with a supply voltage of 230 V~/50 Hz or 115 V~/60 Hz without adjustment.

1. Check that the device is switched off.
2. Plug the power cable into the power connection socket (20).
3. Plug the power cable into a grounded socket.

2.3.2 Connecting to a Computer or Computer Network

Attention!



Inadequate or no grounding can cause malfunctions during operations.

Ensure that all computers and cables connected to the label printer are grounded.

- ▶ Connect the label printer to a computer or network by a suitable cable.

2.4 Switching on the Device

When all connections have been made:

- ▶ Switch the printer on at the power switch (19).
The printer performs a system test, and then shows the system status *ready* in the display (8).

If an error occurs during the system test, the symbol  and type of error are displayed.

3.1 Structure of the Control Panel

The user can control the operation of the printer with the control panel, for example:

- Issuing, interrupting, continuing and canceling print jobs,
- Setting printing parameters, e.g. heat level of the printhead, print speed, interface configuration, language and time of day,
- Start the test functions,
- Control stand-alone operation with a memory module,
- Update the firmware.

Many functions and settings can also be controlled by software applications or by direct programming with a computer using the printer's own commands.

Settings made on the control panel make the basic settings of the label printer.

Notice!



It is advantageous, whenever possible, to make adaptations to various print jobs in the software.

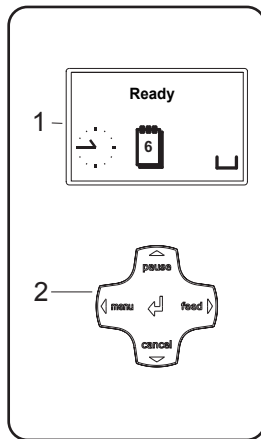

The control panel consists of a graphic display (1) and the navigator pad (2) with five integrated keys.

The graphic display indicates the current status of the printer and the print job, indicates faults and shows the printer settings in the menu.

Fig. 4 Control Panel

3.2 Symbol Displays

The symbols shown in the following table may appear in the status line of the display, depending on the printer configuration. They enable the current printer status to be seen quickly.

Symbol	Description	Symbol	Description	Symbol	Description
	Clock		Ethernet link status		User memory in the clock circuit
	Date sheet		Temperature of the printhead		Used memory
	Date/time digital		PPP funds (Pay Per Print)		Input buffer
	Ribbon supply		Debug window for abc programs		Access to memory card
	Wi-Fi signal strength		Control of the lower display line is handed over to an abc program		Printer is receiving data

Table 1 Symbol displays

3.3 Printer States







State	Display	Description
Ready	Ready and configured symbol displays, such as time  and date 	The printer is in the ready state and can receive data.
Printing label	Printing label and the number of the printed label in the print job.	The printer is currently processing an active print job. Data can be transmitted for a new print job. The new print job will start when the previous one has finished.
Pause	Pause and the symbol 	The printing process has been interrupted by the operator.
Correctable error	 and the type of error and the number of labels still to be printed.	An error has occurred that can be rectified by the operator without interrupting the print job. The print job can be continued after the error has been rectified.
Irrecoverable error	 and the type of error and the number of labels still to be printed.	An error has occurred that cannot be rectified without interrupting the print job.
Critical error	 and the type of error	An error occurs during the system test. <ul style="list-style-type: none"> ▶ Switch the printer off and then on again at the power switch or ▶ Press cancel key. Call Service if the fault occurs persistently.
Power Save Mode	 and the key lighting is switched off	If the printer is not used for a lengthy period, it automatically switches to power save mode. <ul style="list-style-type: none"> ▶ To exit power save mode: Press any key on the navigator pad.

Table 2 Printer states

3.4 Key Functions

The key functions depend on the current printer state:

- Active functions: Labels and symbols on the navigator pad keys light up.
- Active functions light up white in print mode (e. g. **menu** or **feed**).
- Active functions light up orange in the offline menu (arrows, key ↵).





Key	Display	State	Function	
menu	lights	Ready	Ready	To the offline menu
feed	lights	Ready	Ready	Feeds a blank label
pause	lights	Ready	Ready	After the end of a print job, reprint the last label
		Printing label	Printing label	Interrupt print job, printer goes into "Pause" state
		Pause	Pause	Continue the print job, printer goes into "Printing label" state
	flashes		Correctable error	Continue the print job after rectifying the error, printer goes into "Printing label" state
cancel	lights	Ready	Ready	Delete internal memory, the last label can no longer be reprinted.
		Printing label	Printing label	Short press → cancels the current print job Longer press → cancels the current print job and deletes all print jobs
		Pause	Pause	
			Correctable error	
	flashes		Irrecoverable error	
↵	lights		Error	Call Help - Concise information for rectifying the fault will be displayed

Table 3 Key functions in the print mode

Key	Menu	Parameter setting	
		Parameter choice	Numeric value
↑	Return from a submenu	-	Increase of the number at the cursor position
↓	Jump into a submenu	-	Decrease of the number at the cursor position
←	Menu option to the left	Sheets to the left	Cursor shift to the left
→	Menu option to the right	Sheets to the right	Cursor shift to the right
↵	Start of a selected menu option Pressing 2 s: Leaving the offline menu	Confirmation of the selected value Pressing 2 s: Abort without changing the value	

Table 4 Key functions in the offline menu

**Notice!**

For adjustments and simple installation work, use the accompanying Allen key located in the upper section of the print unit. No other tools are required for the work described here.

4.1 Loading Labels or Continuous Media from Roll

4.1.1 Positioning the Media Roll on the Roll Retainer

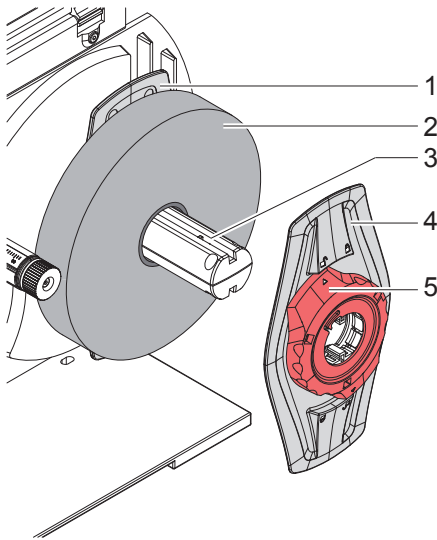

Fig. 5 Loading media from roll

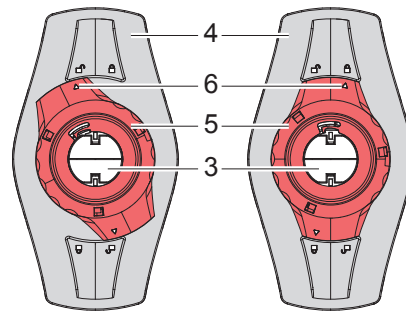



Fig. 6 Margin stop unfixed (left) and fixed (right)

1. Open cover (13).
2. Turn ring (5) counterclockwise, so that the arrow (6) points to the symbol , and thus release the margin stop (4).
3. Remove the margin stop (4) from the roll retainer (3).
4. Load label roll (2) on the roll retainer (3) in such a way that the labels can be inserted into the printhead in the right position. The printing side of the labels must be visible from above.
5. Re-mount the margin stop (4) onto the roll retainer (3). Push the margin stop (4) until both margin stops (1, 4) touch the label roll (2) and a clear resistance is encountered.
6. Turn ring (5) clockwise, so that the arrow (6) points to the symbol , and thus fix the margin stop (4) on the roll retainer (3).

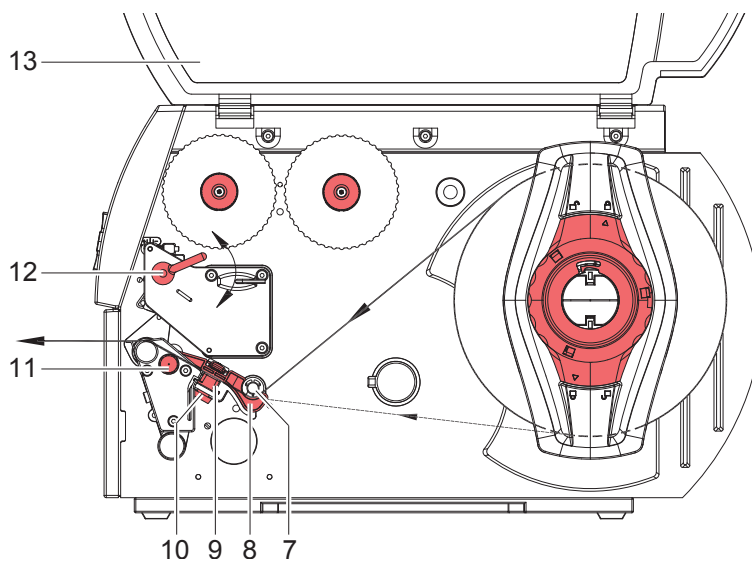

Fig. 7 Material feed path

4.1.2 Inserting a Media Strip into the Printhead

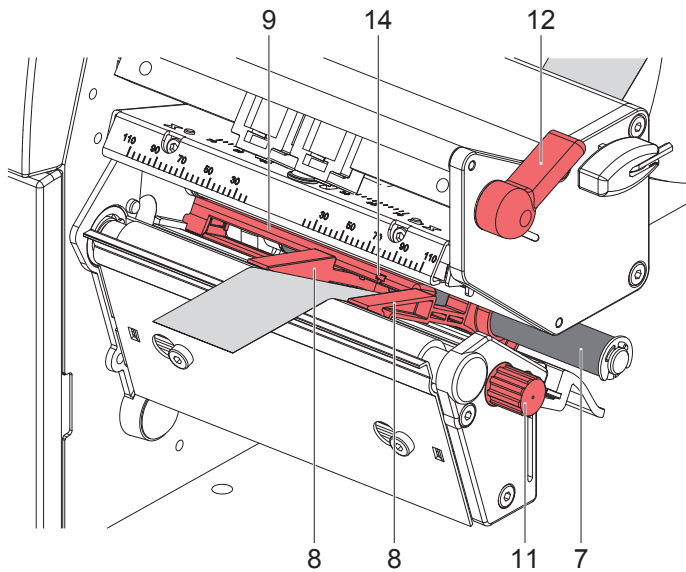

Fig. 8 Inserting a media strip into the printhead

1. Turn lever (12) counterclockwise to lift the printhead.
2. Move guides (8) apart with the knob (11) until the media can pass between them.
3. Push media strip below the guide roller (7) between the guides (8).
4. Guide media strip through the label sensor (9) in such a way that it leaves the print mechanics (6, fig 1) between printhead (10, fig 2) and the print roller (11, fig 2).
5. Move guides (8) against the edges of the material by turning the knob (11).

4.1.3 Setting the Label Sensor

The label sensor (9) can be shifted perpendicular to the direction of paper flow for adaptation to the media. The sensor unit of the label sensor is visible from the front through the print unit and is marked with an indentation (14) in the label sensor retainer. When the printer is switched on, a yellow LED illuminates the sensor position.

- ▶ Loosen the knurled knob (10, fig 7) and position label sensor by moving the knurled knob in such a way that the sensor can detect the label gap or a reflex or cut-out mark.
- or, if the labels deviate from a rectangular shape, -
- ▶ Align label sensor with the front edge of the label in the direction of paper flow.
- ▶ Re-tighten the knurled knob.
- ▶ Turn lever (12) clockwise to lock the printhead.

4.2 Loading Fanfold Labels

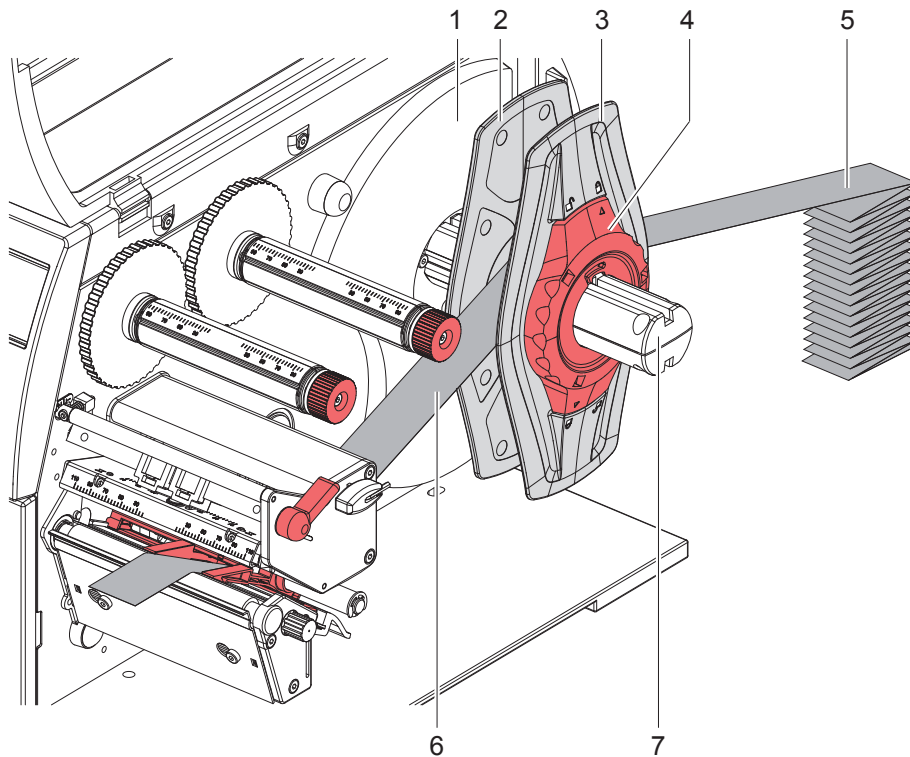



Fig. 9 Loading fanfold labels

1. Position label stack (5) behind the printer.
2. Turn ring (4) counterclockwise, so that the arrow points to the symbol , and thus release the margin stop (3). Leave the margin stop on the roll retainer (7).
3. Push the inner margin stop (2) against the chassis (1) until it stops. Thus the other margin stop (3) will be moved outwards.
4. Push label strip between the margin stops (2,3) to print unit via the roll retainer (7). Ensure that the labels on the strip are visible from above.
5. Push the outer margin stop (3) until both margin stops (2, 3) touch the label strip (6) without clamping or bending it.
6. Turn ring (4) clockwise, so that the arrow points to the symbol , and thus fix the margin stop (3) on the roll retainer.
7. Insert label strip into printhead (▷ 4.1.2 on page 13).
8. Set label sensor (▷ 4.1.3 on page 13).

4.3 Loading Transfer Ribbon

Notice!

With direct thermal printing, do not load a transfer ribbon; if one has already been loaded, remove it.

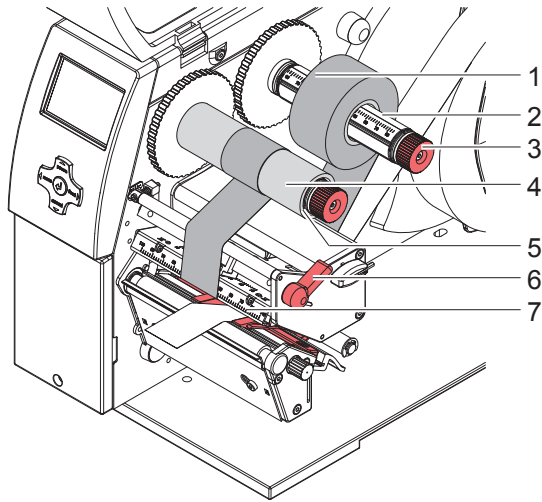

Fig. 10 Load transfer ribbon

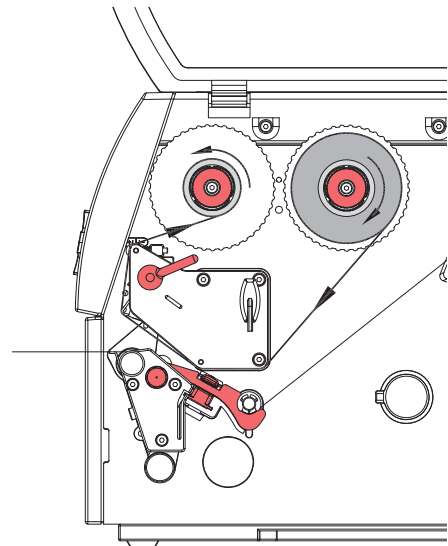

Fig. 11 Transfer ribbon feed path

1. Clean printhead before loading the transfer ribbon (▷ 6.3 on page 18).
2. Turn lever (6) counterclockwise to lift the printhead.
3. Slide transfer ribbon roll (1) onto the ribbon supply hub (3) so that the color coating of the ribbon faces downward when being unwound.
4. Position the ribbon roll in such a way that both ends of the roll show identical scale values.
5. Hold transfer ribbon roll (1) firmly and turn knob (3) on ribbon supply hub counterclockwise until the transfer ribbon roll is secured.

**Notice!**

To rewind the transfer ribbon use a core with a width between the width of the supply roll and 115 mm.

6. Slide suitable transfer ribbon core (4) onto the transfer ribbon take-up hub (5). Position and secure it in the same way as the supply roll.
7. Guide transfer ribbon through the print unit as shown in Fig. 11.
8. Secure starting end of transfer ribbon to middle of the ribbon core (1) with adhesive tape. When using cores which are wider than the transfer ribbon use the scale (7) at the printhead retainer to adjust the path of the ribbon. Ensure counterclockwise rotation direction of the transfer ribbon take-up hub.
9. Turn transfer ribbon take-up hub (5) counterclockwise to smooth out the feed path of the transfer ribbon.
10. Turn lever (6) clockwise to lock the printhead.

4.4 Setting the Feed Path of the Transfer Ribbon

Transfer ribbon wrinkling can lead to print image errors. Transfer ribbon deflection can be adjusted so as to prevent wrinkles.



Notice!
The adjustment is best carried out during printing.

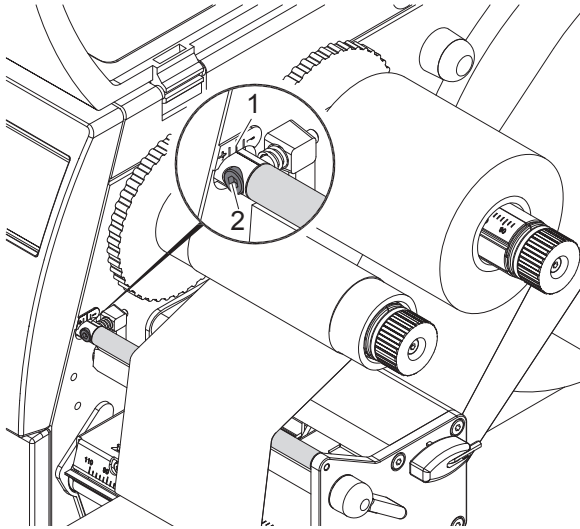

Fig. 12 Setting the feed path of the transfer ribbon

1. Read current setting on the scale (1) and record if necessary.
2. Turn screw (2) with Allen key and observe the behavior of the ribbon.
In the + direction, the inner edge of the ribbon is tightened, and the outer edge is tightened in the - direction.

4.5 Setting the Head Locking System

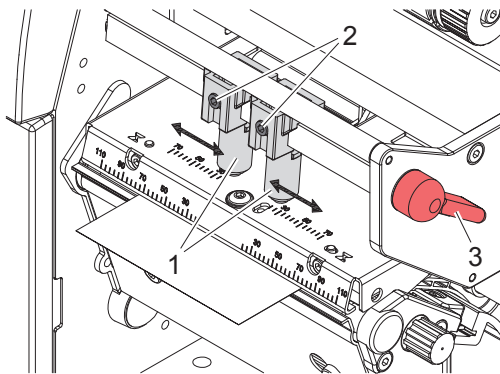

Fig. 13 Setting the head locking system

The printhead is pushed on via two plungers (1). In the basic setting the plungers are set in the middle of the printhead retainer. This setting can be used for the most applications.

If the print density decreases in the outer areas when using very large media, the plungers can be displaced :

1. Turn lever (3) clockwise to lock the printhead.
2. Loosen threaded pins (2) at the plungers (1) with Allen key.
3. Displace plungers symmetrically as necessary maximal to the scale value 70.
4. Tighten the threaded pins (2).

**Attention!****Printhead damage caused by improper handling!**

- ▶ Do not touch the underside of the printhead with the fingers or sharp objects.
- ▶ Ensure that the labels are clean.
- ▶ Ensure that the label surfaces are smooth. Rough labels act like emery paper and reduce the service life of the printhead.
- ▶ Print with the lowest possible printhead temperature.
- ▶ Ensure the ribbon is correctly loaded and that the width is greater than that of the media, being printed.

The printer is ready for operation when all connections have been made and labels and, if applicable, the transfer ribbon have been loaded.

Calibration of the Paper Feed

After the label stock has been inserted, for cutting mode a calibration of the paper feed is required. That way the first label, which is detected by the label sensor, will be transported to the print position and all labels in front will be fed out of the printer. So the calibration avoids, that the first cut label would be too long. That can cause useless first label.

- ▶ Press the **feed** key to start the calibration.
- ▶ Remove the blank labels cut during the calibration.

**Notice!**

Calibration is not necessary if the printhead was not opened between different print jobs, even if the printer was switched off.

6.1 Cleaning Information



Danger!

Risk of death via electric shock!

- ▶ **Disconnect the printer from the power supply before performing any maintenance work.**

The label printer requires very little maintenance.

It is important to clean the thermal printhead regularly. This guarantees a consistently good printed image and plays a major part in preventing premature wear of the printhead.

Otherwise, the maintenance is limited to occasional cleaning of the device.



Attention!

The printer can be damaged by aggressive cleansers.

Do not use abrasive cleaners or aggressive solvents for cleaning the external surfaces or modules.

Contact your local Tyco Electronics representative for cleaning kit information.

- ▶ Remove dust and paper fluff from the print area with a soft brush or vacuum cleaner.
- ▶ The cover of the printer can be cleaned with a standard cleanser.

6.2 Cleaning the Print Roller

Accumulations of dirt on the print roller may impair the media transport and the print quality.

- ▶ Lift the printhead.
- ▶ Remove labels and transfer ribbon from the printer.
- ▶ Remove deposits with Tyco Electronics roller cleaner and soft cloth.
- ▶ If the roller appears damaged, replace it.

6.3 Cleaning the Printhead

Cleaning intervals: thermal transfer printing - every ribbon roll change

Substances may accumulate on the printhead during printing and adversely affect printing, e.g. differences in contrast or vertical stripes.



Attention!

Printhead can be damaged!

Do not use sharp or hard objects to clean the printhead.

Do not touch protective glass layer of the printhead.



Attention!

Risk of injury from the hot printhead line.

Ensure that the printhead has cooled down before starting cleaning.

- ▶ Lift the printhead.
- ▶ Remove labels and transfer ribbon from the printer.
- ▶ Clean print head surface with the approved Tyco Electronics print head cleaner.
- ▶ Allow printhead to dry for 2–3 minutes before commissioning the printer.

7.1 Types of Errors

The diagnostic system indicates on the screen if an error has occurred. The printer is set into one of the three possible error states according to the type of error.



State	Display	Key	Remark
Correctable error		pause flashes cancel lights	▷ 3.4 on page 11
Irrecoverable error		cancel flashes	
Critical fault		-	

Table 5 Error states

7.2 Problem Solution

Problem	Cause	Remedy
Transfer ribbon creases	Transfer ribbon deflection not adjusted	Adjust the transfer ribbon deflection. ▷ 4.4 on page 16
	Transfer ribbon too wide	Use a transfer ribbon slightly wider than the width of label.
Print image has smears or voids	Printhead is dirty	Clean the printhead ▷ 6.3 on page 18
	Temperature too high or low	Decrease or increase temperature via software.
	Unsuitable combination of labels and transfer ribbon	Use different type of ribbon. * Please see NOTE.
Printer does not stop after transfer ribbon runs out	Thermal printing is chosen in the software	Change to thermal transfer printing.
Printer prints a sequence of characters instead of the label format	Printer is in ASCII dump mode	Cancel the ASCII dump mode.
Printer transports label media, but transfer ribbon does not move	Transfer ribbon incorrectly inserted.	Check and, if necessary, correct the transfer ribbon web and the orientation of the label side.
	Unsuitable combination of labels and transfer ribbon	Use different type of ribbon.
Printer only prints each second label	Setting of the size in the software is too large.	Change the size in the software.
Vertical white lines in the print image	Printhead is dirty	Clean the printhead ▷ 6.3 on page 18
	Printhead is defective (failure of heat elements)	Change the printhead.
Horizontal white lines in the print image	Printer is used with the <code>backfeed > smart</code> in the cut or peel-off mode	Set the <code>backfeed > always</code> in the setup.
Print image is irregular, one side is lighter	Printhead is dirty	Clean the printhead ▷ 6.3 on page 18
	Printhead toggle position.	Adjust toggle position ▷ fig 12.1 page 16

Table 6 Problem solution

***NOTE Contact Tyco for recommendation on correct ribbon and media combination.**

7.3 Error Messages and Fault Correction

Error message	Cause	Remedy
ADC malfunction	Hardware error	Switch the printer off and then on. If error recurs call service.
Barcode error	Invalid barcode content, e.g. alphanumeric characters in a numerical barcode	Correct the barcode content.
Barcode too big	The barcode is too big for the allocated area of the label	Reduce the size of the barcode or move it.
Battery low	Battery of the PC card is flat	Replace battery in the PC card.
Buffer overflow	The input buffer memory is full and the computer is still transmitting data.	Use data transmission via protocol (preferably RTS/CTS).
Card full	No more data can be stored on the memory card	Replace card.
Cutter blocked	Cutter cannot return into its home position and stays in an undefined position	Switch off the printer. Remove material. Switch on the printer. Restart print job. Change material
	No cutter function	Switch the printer off and then on. If error recurs call service.
Cutter jammed	The cutter is unable to cut the labels but is able to return into its home position	Press the cancel key. Change material.
Device not conn.	Programming addresses a non-existent device	Either connect this device or correct the programming.
File not found	Requested file is not on the card	Check the contents of the card.
Font not found	Error with the selected download font	Cancel current print job, change font.
FPGA malfunction	Hardware error	Switch the printer off and then on. If error recurs call service.
Head error	Hardware error	Switch the printer off and then on. If error recurs replace printhead.
Head open	Printhead not locked	Lock printhead.
Head too hot	Printhead is overheated	After pausing the print job will be continued automatically. If the fault recurs repeatedly, reduce the heat level or the print speed via software.
Invalid setup	Error in the configuration memory	Re-configure printer. If error recurs call service.
Memory overflow	Current print job contains too much information, e.g. selected font, large graphics	Cancel current print job. Reduce amount of data to be printed.
Name exists	Duplicate usage of field name in the direct programming	Correct programming
No DHCP server	The printer is configured for DHCP, but there is no DHCP server, or the DHCP server is not currently available.	Switch off DHCP in the configuration, and assign a fixed IP address. Please contact your network administrator.
No label found	There are labels missing on the label material	Press pause key repeatedly until printer recognizes the next label on the material.
	The label format as set in the software does not correspond with the real label format	Cancel current print job. Change the label format set in the software. Restart print job.
	Printer is loaded with continuous paper, but the software is set on labels	Cancel current print job. Change the label format set in the software. Restart the print job.
No label size	The size of the label is not defined in the programming.	Check programming.
No Link	No network link	Check network cable and connector. Please contact your network administrator.

Error message	Cause	Remedy
No record found	Refers to the optional memory card; database access error	Check programming and card contents.
No SMTP server	The printer is configured for SMTP, but there is no SMTP server, or the SMTP server is not currently available.	Switch off SMTP in the configuration. Caution! Then a warning cannot be sent by e-mail (EAlert). Please contact your network administrator.
No Timeserver	Timeserver is selected in the configuration, but there is no Timeserver, or the Timeserver is not currently available.	Switch off Timeserver in the configuration. Please contact your network administrator.
Out of paper	Out of label roll	Load labels.
	Error in the paper feed	Check paper feed.
Out of ribbon	Out of transfer ribbon	Insert new transfer ribbon.
	Transfer ribbon melted during printing	Cancel current print job. Change the heat level via software. Clean the printhead ▷ 6.3 on page 18 Load transfer ribbon Restart print job.
	The printer is loaded with thermal labels, but the software is set to transfer printing	Cancel current print job. Set software to direct thermal printing. Restart print job
Protocol error	Printer has received an unknown or invalid command from the computer.	Press the pause key to skip the command or press the cancel key to cancel the print job.
Read error	Read error when reading from the memory card	Check data of the card. Backup data, reformat card.
Remove ribbon	Transfer ribbon is loaded although the printer is set to direct thermal printing	for direct thermal printing remove ribbon
		for thermal transfer printing set the printer in the configuration or in the software to transfer printing
Structural err.	Error in the file list of the memory card, data access is uncertain.	Format memory card.
Unknown card	Card not formatted, Type of card not supported	Format card, use different type of card.
USB error Device stalled	A USB device has been detected, but it is not working.	Do not use the USB device.
USB error Too much current	The USB device consumes too much current.	Do not use the USB device.
USB error Unknown device	Failure to detect USB device	Do not use the USB device.
Voltage error	Hardware error	Switch the printer off and then on. If error recurs call service. It is shown which voltage has failed. Please note.
Write error	Hardware error	Repeat the write process, reformat card.
Write protected	PC card write protection is activated.	Deactivate the write protection.
Wrong revision	Error when updating the firmware. Firmware not compatible with the hardware version	Load the compatible firmware.

Table 7 Error Messages and Fault Correction

8.1 Media Dimensions

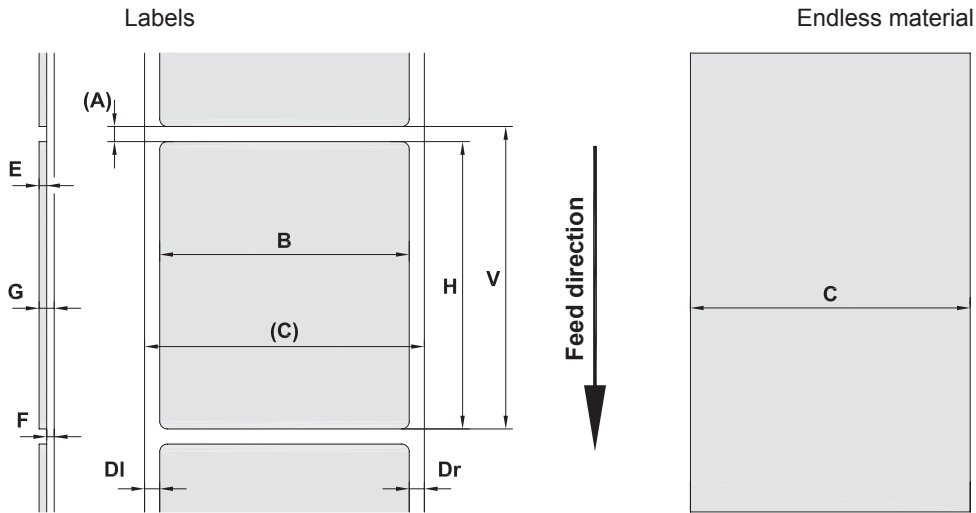

Fig. 14 Label dimensions

Dim.	Designation	Dim. in mm
B	Label width	4 - 106
H	Label height	4 - 1000
-	Tear-off length	> 30
-	Cut length	
	with cutter CU4	> 2
	with perforation cutter PCU4	> 12
-	Perforation length	> 5
A	Label distance	> 2
C	Width of liner	25 - 110
	heat shrink tubing	5 - 110
DI	Left margin	≥ 0
Dr	Right margin	≥ 0
E	Label thickness	0,025 - 0,7
F	Liner thickness	0,03 - 0,1
G	Thickness label with liner	0,055 - 0,8
V	Label feed	> 7
	<ul style="list-style-type: none"> • Small label sizes, thin materials or strong glue can lead to limitations. Critical applications need to be tested and cleared. • Note the bending stiffness ! Material must be flexible to follow the radius of the print roller ! • For narrow materials a higher minimum thickness is required, e.g. Q = 0,4 at C = 5 ! 	

Table 8 Label dimensions

8.2 Device Dimensions

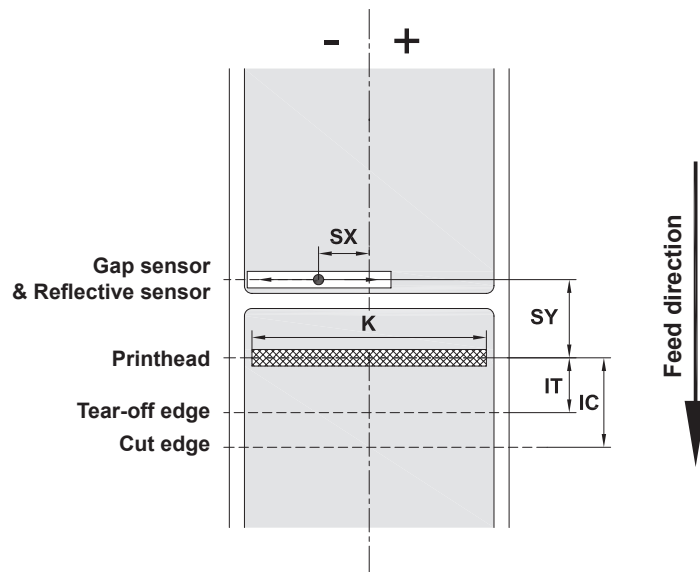

Fig. 15 Device dimensions

Dim.	Designation	Dim. in mm
IC	Distance printhead - cut edge with cutter CU4 with perforation cutter PCU4	18,8 19,5
IT	Distance printhead - tear-off edge	13,5
K	Print width	105,6
SX	Distance gap/reflective sensor - middle of paper track i.e. permissible distance of reflex or cut-out marks from the middle of the material	-53 - ±0
SY	Distance gap/reflective sensor - printhead	46,0

Table 9 Device dimensions

8.3 Reflex Mark Dimensions

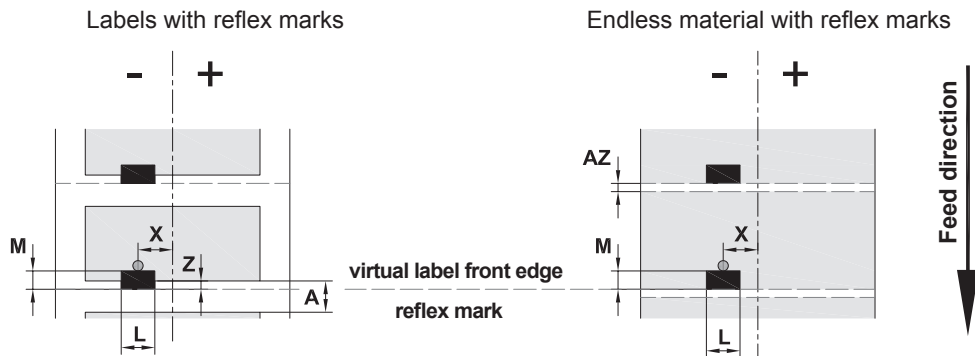
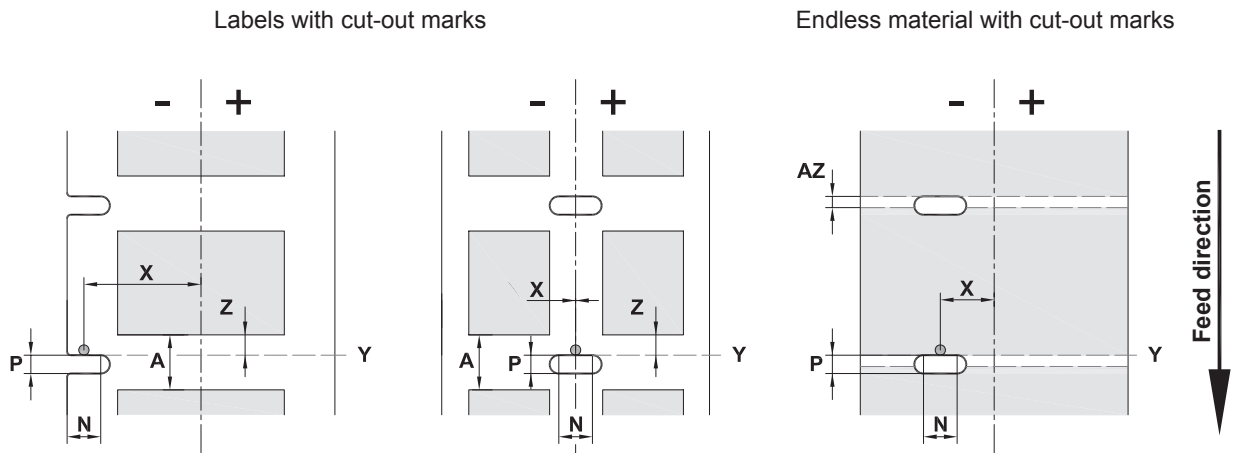

Fig. 16 Reflex mark dimensions

Dim.	Designation	Dim. in mm
A	Label distance	> 2
AZ	Distance between print zones	>2
L	Width of reflex mark	> 5
M	Height of reflex mark	3 - 10
X	Distance mark - material edge	-53 - ±0
Z	Distance virtual label front edge - actual label front edge ▶ Adjust software settings	0 up to A / recomm. : 0
<ul style="list-style-type: none"> • Reflex marks must be on the back side of the material (liner). • Label sensor for reflex marks on the top side on request. • Specification is valid for black marks. • Recognition of colored marks may fail. ▶ Preliminary tests are needed. 		

Table 10 Reflex mark dimensions

8.4 Cut-out Mark Dimensions



for marginal cut-out marks
minimum liner thickness 0,06 mm

Fig. 17 Cut-out mark dimensions

Dim.	Designation	Dim. in mm
A	Label distance	> 2
AZ	Distance between print zones	>2
N	Width of cut-out mark	> 5
P	Height of cut-out mark	2 - 10
X	Distance mark - middle of paper track	-53 - ±0
Y	Sensor recognized virtual label front edge with gap sensor recognition	Rear edge cut-out
Z	Distance recognized front edge - actual label front edge ▶ Adjust software settings	0 up to A-P

Table 11 Cut-out mark dimensions

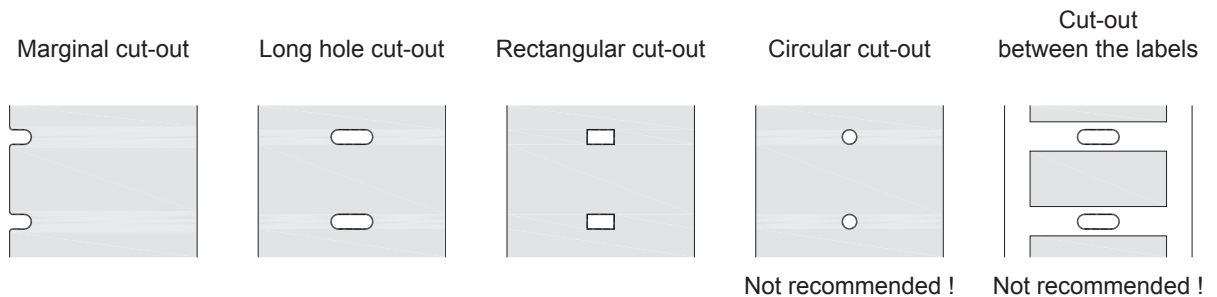

Fig. 18 Samples for cut-out marks

9.1 EU Declaration of Conformity



Tyco Electronics UK Ltd
Faraday Road
Dorcan
Swindon
Wiltshire
SN3 5HH
UK

EU Declaration of Conformity

We declare herewith that as a result of the manner in which the device designated below was designed, the type of construction and the devices which, as a result have been brought on to the general market comply with the relevant fundamental regulations of the EU Rules for Safety and Health. In the event of any alteration which has not been approved by us being made to any device as designated below, this statement shall thereby be made invalid.

Device:	Transfer Printer / Thermal-direct Printer
Type:	TE3112
Applied EU Regulations and Norms:	
Directive 2006/95/EC relating to electrical equipment designed for use within certain voltage limits	<ul style="list-style-type: none"> • EN 60950-1:2006 • EN 61558-1:2005
Directive 2004/108/EC relating to electromagnetic compatibility	<ul style="list-style-type: none"> • EN 55022:2006 • EN 55024:1998+A1:2001+A2:2003 • EN 61000-3-2:2006 • EN 61000-3-3:1995+A1:2001+A2:2005
Signed for, and on behalf of the Manufacturer :	
<p>Tyco Electronics UK Ltd Faraday Road, Dorcan, Swindon, Wiltshire SN3 5HH, UK</p>	 <p>John Swift Product Engineering Manager</p>

9.2 Other Licences

- FCC** Requirements of the FCC regulations part 15 for class A computers.
Under disadvantageous circumstances, the operation of these devices may cause interference with radio or TV reception, which has to be eliminated by the operator.

A		
Adapting the roll retainer	12	
C		
Cleaning		
printhead	18	
print roller	18	
Cleaning information	18	
Connecting	8	
Contents of delivery	8	
Control panel	9	
Correctable error	10	
Critical error	10	
Cut-out marks	25	
Cut mode	17	
D		
Device dimensions	23	
Device overview	6	
E		
Environment	4, 5	
Errors		
correction	20	
display	19	
messages	20	
states	19	
types	19	
EU Conformity Declaration	26	
G		
Graphic display	9	
H		
Head locking system, setting	16	
Help calling	11	
I		
Important information	4	
Intended use	4	
Irrecoverable error	10	
K		
Key		
cancel	11	
enter	11	
feed	11	
menu	11	
pause	11	
Key functions	11	
offline menu	11	
print mode	11	
L		
Label sensor		
setting	13	
Lithium battery	5	
Loading fanfold labels	14	
Loading labels	12	
Loading labels from roll	12	
Loading transfer ribbon	15	
M		
Margin stop	6, 12	
Media dimensions	22	
N		
Navigator pad	9	
O		
Offline menu	11	
P		
Pause	10	
Power save mode	10	
Power supply	4	
Printer states	10	
Printhead		
cleaning	18	
damage	17	
Printing label	10	
Print roller, cleaning	18	
Problem solution	19	
R		
Ready	10	
Reflex marks	24	
Ribbon deflection, setting	16	
S		
Safety instructions	4	
Service work	5	
Setting-up	8	
Supply voltage	8	
Switching on	8	
Symbol displays	9	
U		
Unpacking	8	
V		
Voltage	4	
W		
Warning stickers	5	

